



V-ARMOR SERIES

SVEX-Q18

Explosion Proof PTZ Camera

The **SVEX-Q18** adopts advanced production techniques and matured quality management system to make its excellent quality performance and appearance a leading position in explosion proof monitoring products. It can be used in flammable and explosive environment.

Strictly according to European Directive EC/94/9 and EN50014, Standards of GB3836.1-2000 GB3836.1—2000 Electrical apparatus for explosive atmosphere: General requirements, GB3836.2-2000 Electrical apparatus for explosive atmosphere: Flameproof 'd' and GB12476.1-2000 Electrical apparatus for explosive dust: Using enclosure and limiting surface temperature for protecting electrical apparatus It can be used in petroleum, chemical industry, port, mine, army and several other location.



SVEX-Q18 with high performance color integrated camera, 23X optical lens, 10X digital zoom could adjust pan tilt speed according to lens location to keep a clear quality image. It owns low lux technique and color B/W auto change, digital picture up/down and freeze function. SVEX-Q18 with multiple protocols to with 64 presets to work in any extreme weather conditions.

Key Features

- 304 or 316L stainless steel material
- Support multiple control protocols
- 360° pan continuous rotation
- 120° tilt rotation
- Support advanced OSD menu
- Ceiling mounting for indoor application

V-ARMOR SERIES SVEX-Q18

Explosion Proof PTZ Camera



Specifications

SVEX-Q18

CERTIFICATE	
Ex-Marking	Ex II 2G EExd IIB+ H2 T6
Certificate	Nemko 05ATEX1
Scanning System	1:1 Progressive scanning
Sensor	1/4" CCD
Line Scan	15.625KHz
Frame Scan	50Hz
Pixel	795(H x) 596 (V)
Lens	23x optical zoom auto/focus F1.6~3.7, f=3.6~82.8mm / 10x digital
Min Focus	0.01m(W) / 1.0m(T)
View angle	54°(W) / 2.5°(T)
Min Lux	0.05Lux (Day)/ 0.01Lux (Night)
TVL	540TVL(C)/ 600TVL (B/W)
S/N Ratio	> 50dB
Video Output	BNC / 1.0±0.2Vp-p / 75Ω
ENVIRONMENTAL	
Air pressure	86~106KPa
Temperature	-4°F~140°F (-20°C ~ +60°C)
Humidity	≤95%RH [77°F (+25°C)]
ELECTRICAL	
Input Voltage	100VAC~240VAC, 50/60Hz
Current	≤300mA
Power	<50W
Communication	RS-485
Communication rate	2400 / 4800 / 9600 / 19200 bps
Protocol	Multiple including Pelco D/P
Preset	128
Preset Accuracy	±0.1°
Video Output	1.0±0.2Vp-p / 75Ω
Cable connection	6-core composite cable

Veilux Inc
802 Greenview Dr. Suite 200, Grand Prairie, TX 75050, USA
Ph: 214-635-4855 Fax: 214-988-2858
www.veilux.net

Specifications

SVEX-Q18

MECHANICAL	
Material	Stainless steel 304 or 316L
Finish	Electro-polish
IP	IP68
Pan	360° continuous pan rotation
Tilt	-90°~+30°
Pan Speed	0.1°/S ~ 60°/S
Tilt Speed	0.1°/S ~ 60°/S
Weight/Shipping weight	48.5 lb (22Kg) / 57.3 lb (26Kg)
Mounting	Ceiling mount or wall mount

Dimensions

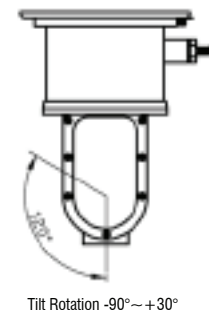
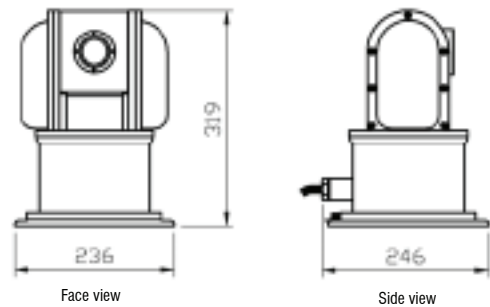

Mounting Size

